



**1/16 L'estrage Street Glenside SA**

1 1 1

This unit requires major refurbishment as it has been lived in and has been neglected for approximately 20 years by current ownership.

**Price** : \$ 265,000

**View** : <https://www.bruse.com.au/sale/sa/eastern-suburbs/glenside/residential/unit/7593641>

The unit is in a bad state but a great opportunity in this wonderful location.

This is being sold under a Supreme Court Order No CIV-22-14190 and is priced accordingly.

This is a one-bedroom home unit with a kitchen, dining and living area and bathroom.



**Bevan Bruse**  
08 8431 8181



**Theon Bruse**  
08 8431 8181

The plumbing is working, the power is on. It really is just a unit to refurbish, put a new kitchen in, redo the bathroom, add new floor coverings and repaint and you have a home unit in a marvellous location.

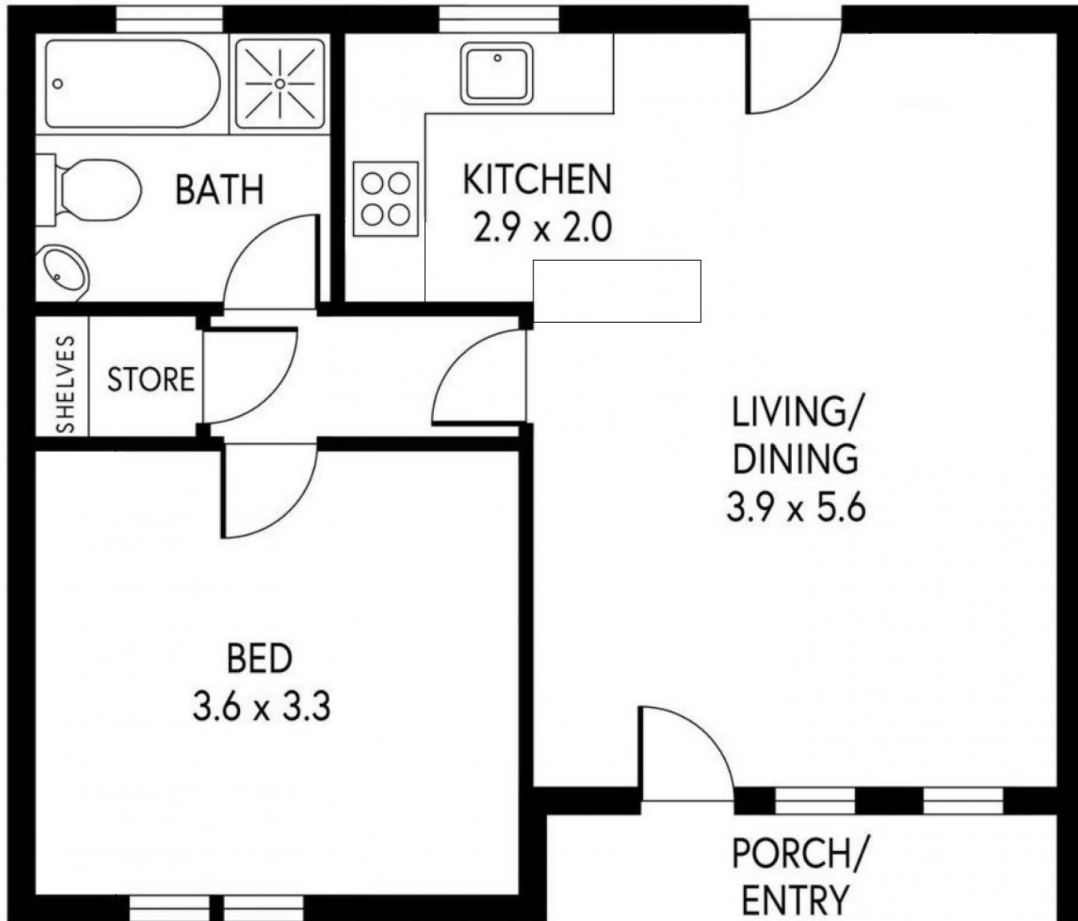

This floorplan is for illustration purposes only and all measurements are approximate. Any fixtures shown may not necessarily be included in the sale contract and is essential that any queries are directed to the agent. Any information that is intended to be relied upon, should be independently verified. Neither the agent, vendor or contracted illustrators take any responsibility of any omission, wrongful inclusion or topographical error which may occur in this drawing as it is an artistic impression only. While every endeavor has been made to verify the correct details in the publication, neither the agent, vendor nor contracted typesetter accept liability for any error or omission.

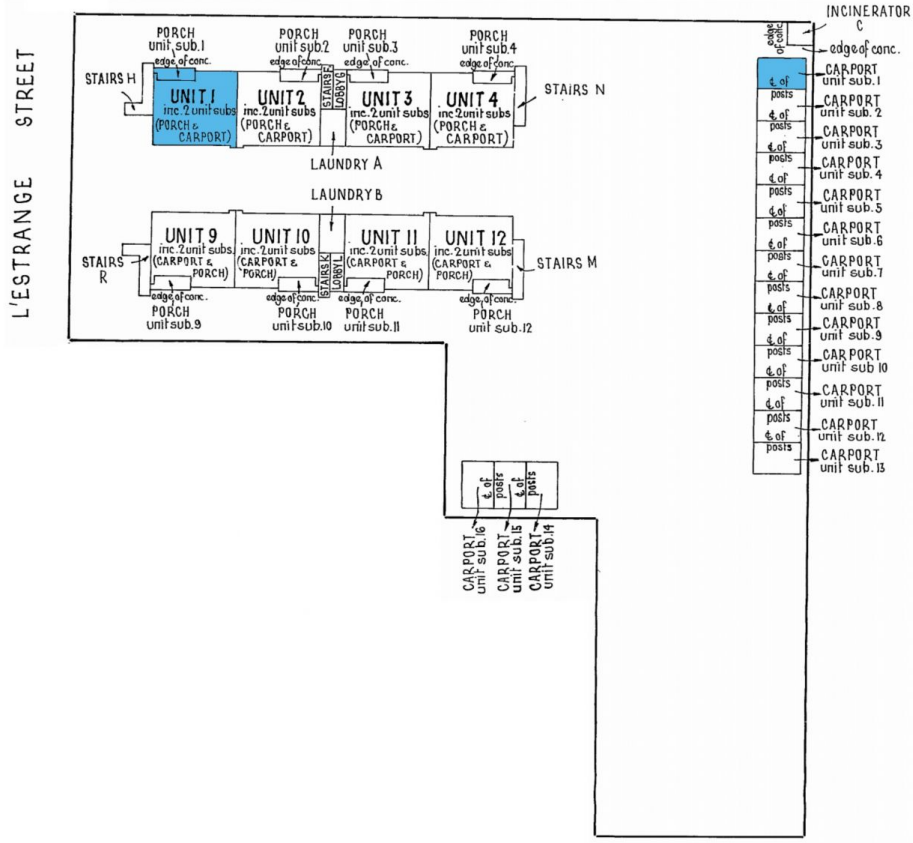

- INCINERATOR C
- edge of conc.
- 4 of posts
- CARPORT unit sub.1
- 4 of posts
- CARPORT unit sub.2
- 4 of posts
- CARPORT unit sub.3
- 4 of posts
- CARPORT unit sub.4
- 4 of posts
- CARPORT unit sub.5
- 4 of posts
- CARPORT unit sub.6
- 4 of posts
- CARPORT unit sub.7
- 4 of posts
- CARPORT unit sub.8
- 4 of posts
- CARPORT unit sub.9
- 4 of posts
- CARPORT unit sub.10
- 4 of posts
- CARPORT unit sub.11
- 4 of posts
- CARPORT unit sub.12
- 4 of posts
- CARPORT unit sub.13

- 4 of posts
- CARPORT unit sub.16
- 4 of posts
- CARPORT unit sub.15
- 4 of posts
- CARPORT unit sub.14